

Reg. No:

| | | | | | | | | |
|--|--|--|--|--|--|--|--|--|
| | | | | | | | | |
|--|--|--|--|--|--|--|--|--|

SIDDHARTH INSTITUTE OF ENGINEERING & TECHNOLOGY:: PUTTUR
(AUTONOMOUS)**B.Tech I Year II Semester Supplementary Examinations Dec 2019**
ENGINEERING GRAPHICS & DESIGN
(CE, EEE, ME & AGE)

Time: 3 hours

Max. Marks: 60

(Answer all Five Units 5 x 12 = 60 Marks)

UNIT-I

- 1 Draw an ellipse(half ellipse by concentric circle method and half by rectangle method) **12M**
having major axis is equal to 100 mm and the minor axis is equal to 70 mm

OR

- 2 The vertex of a hyperbola is 60 mm from its focus. Draw the curve, if the eccentricity is $3/2$. Draw a normal and a tangent at a point on the curve, 75 mm from the directrix. **12M**

UNIT-II

- 3 Draw the projections of the following points, keeping the distance between the projectors as 30mm on the same reference lines. **12M**
A – 30mm above HP and 40mm in front of VP
B – On HP and on VP
C – 25mm below HP and 35mm behind VP
D – 30mm below HP and 40mm in front of VP
E – On HP and 30mm in front of VP
F – 30mm above HP and 40mm behind VP

OR

- 4 Draw the projections of a straight line AB of 70 mm long, in the following positions: **12M**
i) Perpendicular to HP, 30 mm in front of VP and one end 25 mm above HP
ii) Perpendicular to HP, 30 mm in front of VP and one end on HP
iii) Perpendicular to HP and in VP and one end on HP

UNIT-III

- 5 An equilateral triangular plane ABC of side 40mm has its plane parallel to VP and 20mm away from it. Draw the projections of the plane when one of its sides is **12M**
(i) Perpendicular to HP (ii) parallel to HP and (iii) inclined to HP at an angle of 45° .

OR

- 6 Draw the projections of a cone, base 30 mm diameter and axis 50 mm long, resting on HP on a point of its base circle with the axis making an angle of 45° with HP and its top view making an angle of 30° with VP. **12M**

UNIT-IV

- 7 A pentagonal pyramid with edge of base 25 mm and axis 65 mm long, its base is resting on HP. It is cut by a section plane, inclined at 60 degree to HP and perpendicular to VP at bisects the axis. Draw the projections and obtain the true shape of the section. **12M**

OR

- 8 A square prism of side of base 40 mm and axis 80 mm long, is resting on its base on HP such that, a rectangular face of it is parallel to VP. Draw the development of the prism. **12M**

UNIT-V

- 9 Draw three views of the blocks shown pictorially in figure according to first angle projection.

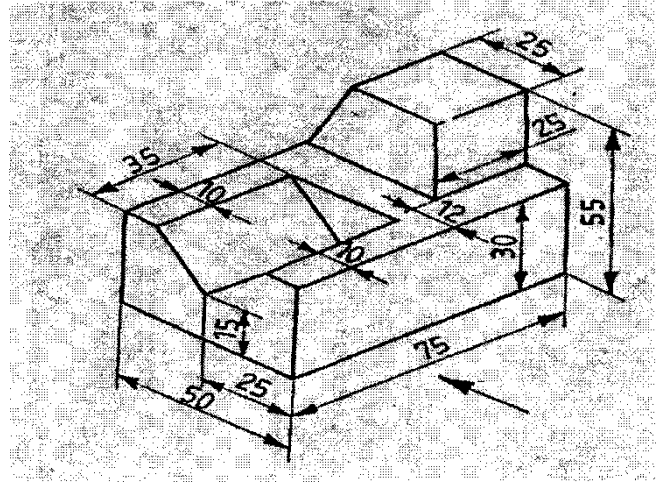

12M

OR

- 10 Draw the isometric view of the following sketch.

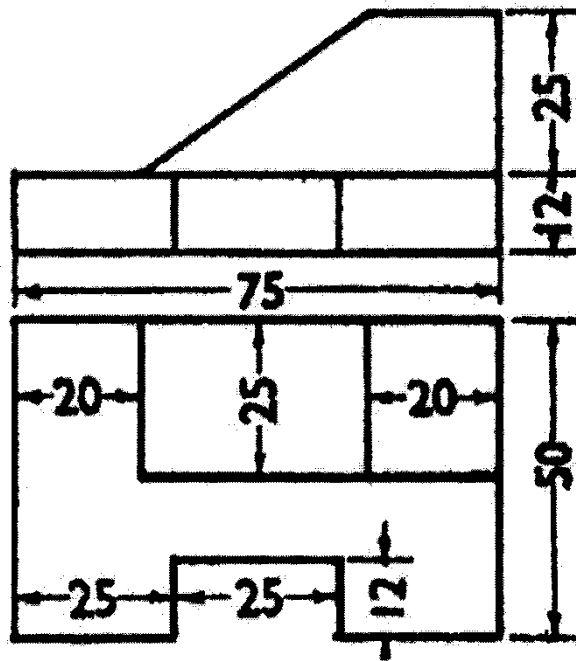

12M

*** END ***